

TRAY TURNER

Patented automatic tray turning device

Automatic tray turning

The Tray Turner is an all-round tray turner with a capacity of up to 120 trays per minute. It turns any sealable tray from either short side or long side leading.

Complete tray turning control allows the device to gently turn the trays at high speeds, without affecting the actual product or position of the product inside the tray.

The Tray Turner can be adjusted for different tray formats and is constructed with automatic speed regulation from the denester.

Tray Turner comes including a conveyor, which is driven by a drum motor. It can be used in combination with e.g. INTRAY Step Loader or INTRAY Easy Loader, but can also be integrated into existing lines as a stand-alone machine.

The complete tray turning control ensures the product maintains its position in the tray.

Technical specifications TRAY TURNER

Specifications	
Capacity	Up to 120 trays per minute (tray depending)
Highlights	Patented turning system
	Recipe controlled by Intray denester
	Compact length
	Conveyor driven by drum motor with frequency converter
	By-pass option

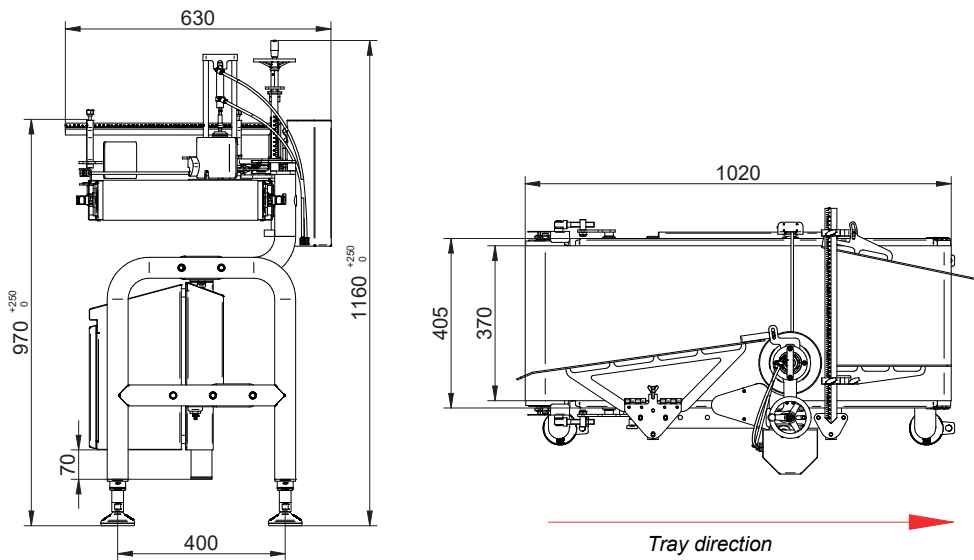

Specifications and photos are intended as a guide and can be changed by QUPAQ without notice. We make reservations for misprints and typing errors.